



# DIGITAL COMMANDER

DESIGNED BY FRED M. MARKS

## THREE CHANNEL SYSTEM KIT

### TRANSMITTER

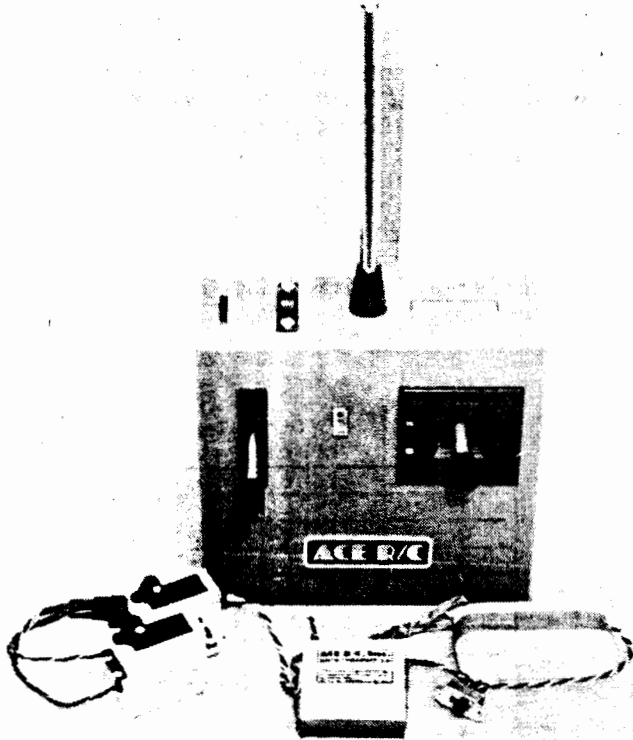

#### I. INTRODUCTION

Our Digital Commander transmitter is capable of providing from one to seven channels of completely linear digital control. Although we don't see the need for more channels, the transmitter is capable of providing up to nine channels with a minor modification.

The transmitter features a commutated encoder, i. e., all timing functions are performed by one timing circuit instead of one per channel. Thus, there is just one component in the entire encoder that requires an expensive, temperature stable capacitor instead of eight or so. In addition, we have eliminated all diodes in the encoder--one of the principal points for errors in most kits. This same feature permits us to use a single "bus" wire to each control pot plus one to a second pot terminal. The result--14 solder joints where most sets have 42; 28 fewer points for a failure. This combination of features permits the lowest parts count for any transmitter available for six or seven channels. There are just 25 components that perform the encoding

function. This contrasts with the usual discrete component encoder that requires from fifty to seventy-five components. The encoder is voltage regulated and completely stable down to six volts.

The RF section delivers a solid 600 milliwatts radiated output (1 watt into the final RF amplifier).

The RF section can be made into a plug-in module that permits changing from one frequency to another or even to another of the three bands used for RC in about 5 minutes.

#### II. TRANSMITTER DESIGN

##### A. THE ENCODER

This is a commutated encoder; that is, it employs only one set of timing circuitry for all channels instead of one set per channel as required by conventional encoders. The control input to the timing circuit steps sequentially from one control potentiometer to the next until a complete frame of information is encoded. This function of stepping sequentially is termed commutation.

The reason for the use of a commutated encoder will be evident upon review of the schematic in that the complete encoder, including voltage regulation and power supply filtering, consists of just 25 components excluding the control potentiometers. Several current encoders have that many diodes alone!

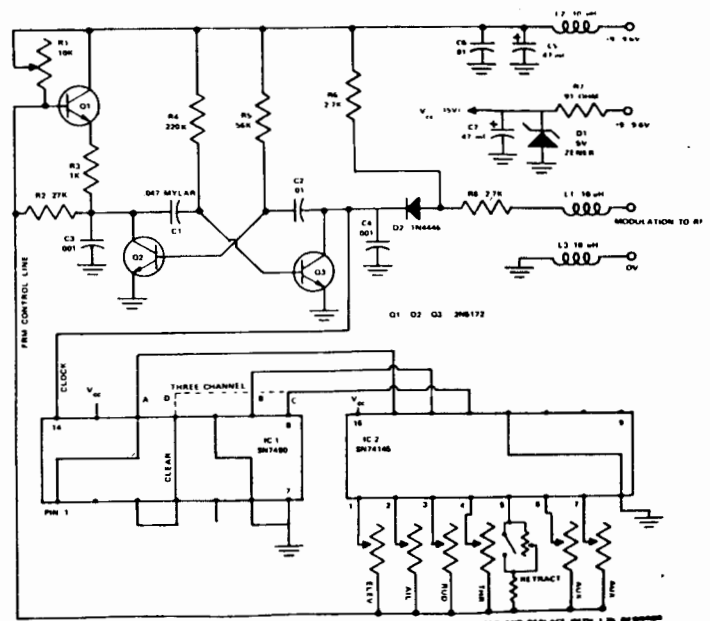

ENCODER SCHEMATIC

FIGURE A-1

The encoder (see Figure A-1) consists of a free-running multivibrator (FRM) that performs the timing function, a control input buffer for this multivibrator, and two integrated circuits that commutate control of the multivibrator time constant from one control input to another.

The free-running multivibrator consists of Q2 and Q3, accompanying resistors R1 through R8, and capacitors C1 thru C4. For purposes of reference, we shall describe the period when the collector of Q2 is "high", i. e., nearly 9.6 volts. This occurs when Q2 is biased "off", i. e., its base is near ground voltage.

The FRM changes state in a clocklike manner, that is, it switches state at a regular interval that is dependent on the value of the related resistors and capacitors. Its period of ON-time may equal OFF-time or they may be varied independently. In our case, we have chosen to fix the OFF-time at 250 microseconds, by selection of the values shown for C2 and R5. This period is the chosen nominal width of the modulation pulse we wish to transmit. The ON-time is variable.

ON-time is set by the value of C1, R4, and the voltage level at the emitter of Q1. For the moment, let us imagine that Q1 has been replaced by a fixed resistor of value RT. The FRM will then run at an OFF-time of 250 microseconds and an ON-time set by RT, R3 and R4 but without any variation.

The goal is to make the ON-time variable about a nominal time of 1.5 milliseconds (ms) by the amount  $\pm 0.5$  ms; i. e., it can be shortened to 1.0 ms or lengthened to 2.0 ms and be continuously variable between these extremes. If we make the imaginary fixed resistor RT mentioned above a variable resistor (potentiometer), then we can control the FRM between these extremes. Q1 then can be viewed as the variable resistor. As Q1 "turns on"; i. e., its emitter is permitted to become more positive, the ON-time period increases and conversely. The variation in the bias level for Q1 is controlled sequentially by each of the ladder of control potentiometers. (Recognize that the retract function is just another form of the control arrange-

ment to permit a switched function that is either 1.0 ms or 2.0 ms for purposes of controlling a two-position function such as retractable landing gear, flaps, and the like.)

Since Q1 is an NPN, it is biased off as the base goes more negative and conversely. Our task now becomes one of providing (1) the bias required to permit a nominal control time period of  $1.5 \text{ ms} \pm 0.5 \text{ ms}$ , and (2) the bias required to produce a synchronization pause of around 4.5 ms between each frame of pulses. IC-1 and IC-2 permit this to be done and also are responsible for the extreme simplicity of the encoder.

IC-1 is a decade counter that converts decimal inputs to binary coded outputs. The logic code for IC-1 shows that it takes sequential clock pulses and produces binary coded outputs at A, B, C, and D. This is really no different from counting decimally except that our friend can only count to one! Thus the A output goes high (1) on the first clock pulse, then low (0) on the second. This is just the same as counting to nine then making the last significant place zero while the second becomes a one to form 10. When A goes low, it "carries" to the next significant place just as we did in going from nine to ten and the B output goes high. It cannot go low again until A goes low once more. The same relationship is true for B versus C and for C versus D. Thus, A changes state with every count, B with every other count, C with every fourth count, and D with every eighth count.

IC-2 is a binary coded decimal (BCD) to decoder driver. Its usual function is to accept the binary coded data characteristic of binary logic computation and convert it to a "one of ten" output. We shall explain the manner in which it does this a bit later. For our purposes, the SN74145 has one outstanding characteristic; it is an open-collector TTL device. That is, the drive transistors are normally used to drive display devices and there is no internal collector load. This is important because it automatically provides the isolation needed to keep the control pots separated from each other when the outputs (1 through 7, and 9 through 11) are high. It is this feature that

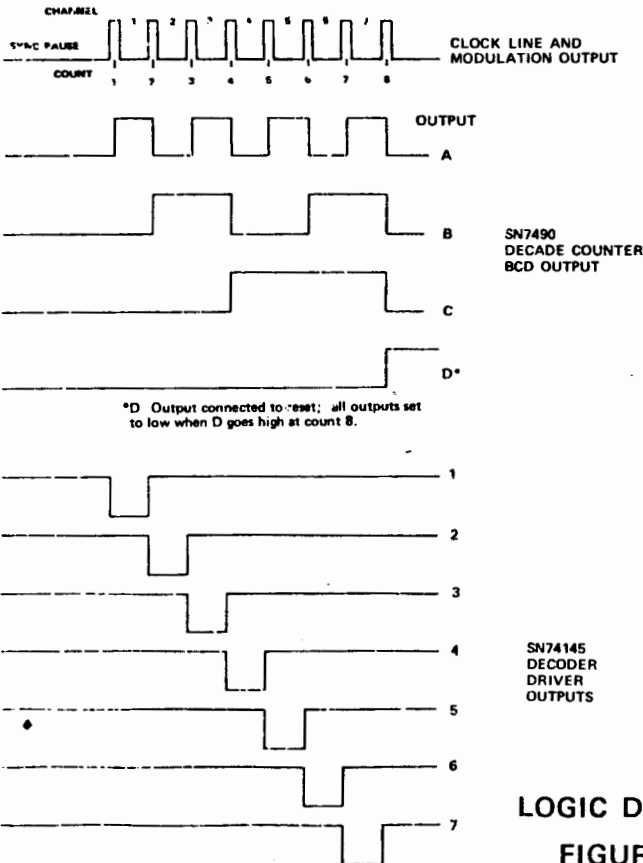

LOGIC DIAGRAMS  
FIGURE A-2

COUNT	OUTPUT			
	D	C	B	A
0	L	L	L	L
1	L	L	L	H
2	L	L	H	L
3	L	L	H	H
4	L	H	L	L
5	L	H	L	H
6	L	H	H	L
7	L	H	H	H
8	H	L	L	L
9	H	L	L	H

TRUTH TABLE-SN7490 DECADE COUNTER  
H=HIGH LEVEL L=LOW LEVEL

INPUT				OUTPUT LOW
D	C	B	A	
L	L	L	L	0
L	L	L	H	1
L	L	H	L	2
L	L	H	H	3
L	H	L	L	4
L	H	L	H	5
L	H	H	L	6
L	H	H	H	7
H	L	L	L	8
H	L	L	H	9

TRUTH TABLE-SN74145 BCD TO DECODER DRIVER  
H=HIGH LEVEL L=LOW LEVEL

permits the elimination of blocking diodes needed where other counting devices such as shift registers are used.

As the SN74145 steps through the sequence, the outputs go low as shown in the accompanying logic code. When the inputs A through D are low, then all outputs are high. Thus Q1 is biased strongly ON and the FRM will have the long (4.5 ms) period required for synchronization.

When the FRM reaches the end of the sync pause and goes OFF for 250 microseconds, a frame of information begins, i. e., it issues the sync or start pulse. This sync pulse appears as a 250 microsecond pulse of 9 volts amplitude at the collector of Q3. It then proceeds via D2 and R8 to the modulator in the RF section. However, notice that it is also connected to the "clock" input of IC-1 at pin 14.

Those familiar with IC's will be aware that there are counters that do binary counting along with the decoding function of the SN74145 all on one chip. However, those devices must count all the way to ten before they can start over unless auxiliary "clear" circuitry is used. The SN7490 has the feature of being able to clear itself and we have made use of it. Notice that the D output (pin 11 of IC-1) is connected to the clear input (pin 3-4). As soon as the count reaches eight (remember we need one more pulse than we have channels, i. e., eight pulses for seven channels) and D starts to go "high", IC-1 is cleared, i. e., all outputs go low. Looking at the code for IC-2, we recall that all outputs will be high and we now start a new sync pause and the frame is complete. One could also use the same approach to stop the count at 4 (reset connected to C) to provide three channels or by connecting B to reset to stop the count at two, provide for one channel. We connect the reset to C in the Three Channel System version to delete the need for the 1.2K resistors in the unused channels.

While we chose to stop the encoder at 3 or 7 channels, it is capable of producing 9 channels for special applications. To do this, pins 3 and 4 of IC-1 must be tied to ground, and the D output from IC-1 connected to pin 12 of IC-2. Pin 12 is no longer tied to ground. Control pots are added as for 1-7 at pins 9 and 10.

## B. BATTERY CONDITION METER

The meter is a miniature expanded scale voltmeter using a zener diode/resistor network and calibrated so the meter moves through the green range and the one small red segment

between 9 and 7 volts. When the needle moves into the LARGE red segment, it is time to change the 9V battery (Eveready 276, Mallory M1603 or equiv.)—solid operation is to be expected down to 7 volts. About 10 hours of operation can be expected from a good fresh battery.

## C. THE RF SECTION

The RF section (Figure B) is quite simple. A crystal oscillator operating at the desired frequency (no doubling or tripling, etc.) produces the unmodulated, unamplified RF. The oscillator is formed of R1, R2, R3, C1, C2, L1, Q1 and the crystal. R4 drops the supply voltage to the oscillator. The RF is coupled to an intermediate stage amplifier and modulator formed by Q2, Q3, L2, C3 and related loading resistors and shaping capacitors. From the modulator-amplifier, C7 couples the RF to the final amplifier, Q4. RFC-2, C4, C5, C6, and L3 form the final RF filter and loading for a 39½ inch whip antenna.

## D. CONVERSION TO 9.6V NI-CD OPERATION

If desired, the Three Channel Transmitter can easily be converted to 9.6V Ni-cd operation. You will need to obtain an eight cell pack of at least 400 mah capacity and replace the dry battery with it. Make sure you maintain proper polarity!

You will need to install a charge jack in the transmitter to charge the batteries—we recommend a Deans charge connector set (Ace No. 19K55, \$1.65) because it only requires drilling in the case at a convenient spot. Wire the charging jack to the power switch: red to lug 5 and black to lug 6. Wire the male charging plug to the appropriate charger, making sure you maintain proper polarity. Before charging or turning the transmitter on, double check that positive from the charger goes through the switch and hooks to positive on the battery pack and that positive from the battery pack goes through the switch and hooks to positive (red) going to the encoder. Check the negative lead also.

Since the transmitter is working at a higher voltage, the battery condition meter will no longer give you a valid reading. If you remove the meter and send it to Ace R/C, Inc., Box 511, Higginsville, Mo. 64037, we will convert and re-calibrate it for a \$2 handling fee. When you get it back, it will be set up as follows: As long as the needle is in the green it is safe to operate. As the needle moves into the LARGE red segment, the voltage has reached a critical level (9.4V) and its time to recharge before resuming operation.

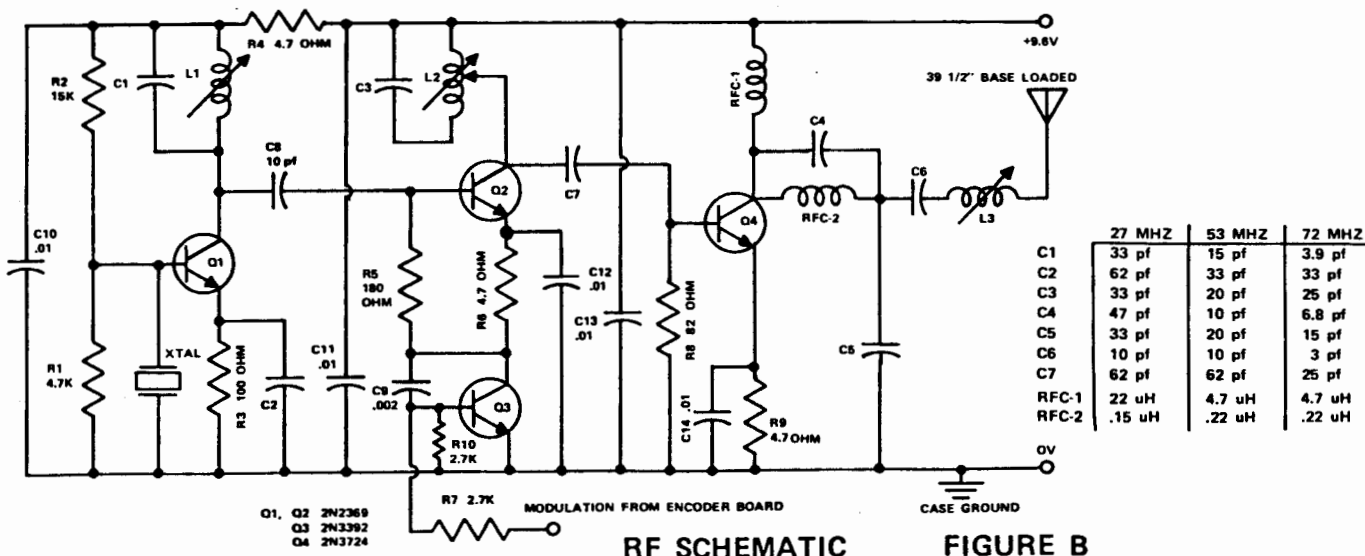

# THREE CHANNEL TRANSMITTER PARTS LIST

( ) 1	Assembled and Tuned RF Deck	( ) 1	Two Axis Stick Assembly with Pots and Hardware
( ) 1	Frequency ID Plate	( ) 1	Single Axis Stick Assembly with Pot and Hardware
( ) 1	FCC Sticker	( ) 1	Trim Assembly, with Pot and Hardware
( ) 1	Encoder PC Board	( ) 3	10 uhy Chokes
( ) 1	Punched Case	( ) 1	SN7490 IC
( ) 1	39½" Antenna	( ) 1	SN74145 IC
( ) 1	DPDT Switchcraft Switch	( ) 3	2N5172
( ) 1	Switch Guard	( ) 1	1N751A
( ) 1	Battery Condition Meter	( ) 1	1N4446
( ) 1	91 ohm (white, brown, black)	( ) 2	.01 Disc Cap
( ) 1	1K (brown, black, red)	( ) 2	.001 Disc Cap
( ) 2	2.7K (red, violet, red)	( ) 1	.047 Mylar Cap
( ) 1	27K (red, violet, orange)	( ) 2	47 mf Tantalum Cap
( ) 1	56K (green, blue, orange)	( ) 1	Antenna Mount and Hardware
( ) 1	220K (red, red, yellow)	( ) 2	2-56 x 1/4" Flat Head Bolts
( ) 1	10K Trim Pot	( ) 1	4-40 x 1/4" Bolt
		( ) 2	4-40 x 3/8" Bolts
		( ) 1	4-40 Nut
		( ) 2	No. 4 Lock Washer
		( ) 4	No. 4 Self Tap Screws
		( ) 1	Encoder Board Bracket
		( ) 3"	1/8" Foam Tape
		( ) 3"	1/8" Heat Shrink Tubing
		( ) 4	Vinyl Sleeving
		( ) 24"	Solder
		( ) 5"	Grey Wire
		( ) 15"	Red and Black Wire
		( ) 8"	Green Wire
		( ) 1	Battery Connector

## III. ENCODER BOARD ASSEMBLY

- ( ) Reread the PC Board Wiring section of the "Kit Builder's Hints".
- ( ) Mount and solder the components on the encoder board, being careful to note the positions of the dots and the IC's, the

flat sides of the transistors, the banded ends of the diodes, and the polarity of the tantalum capacitors.  
 ( ) When all components are soldered into place, clip the excess leads from the bottom of the board, scrub off the solder resin using an old toothbrush and alcohol and check for solder bridges or missed joints.

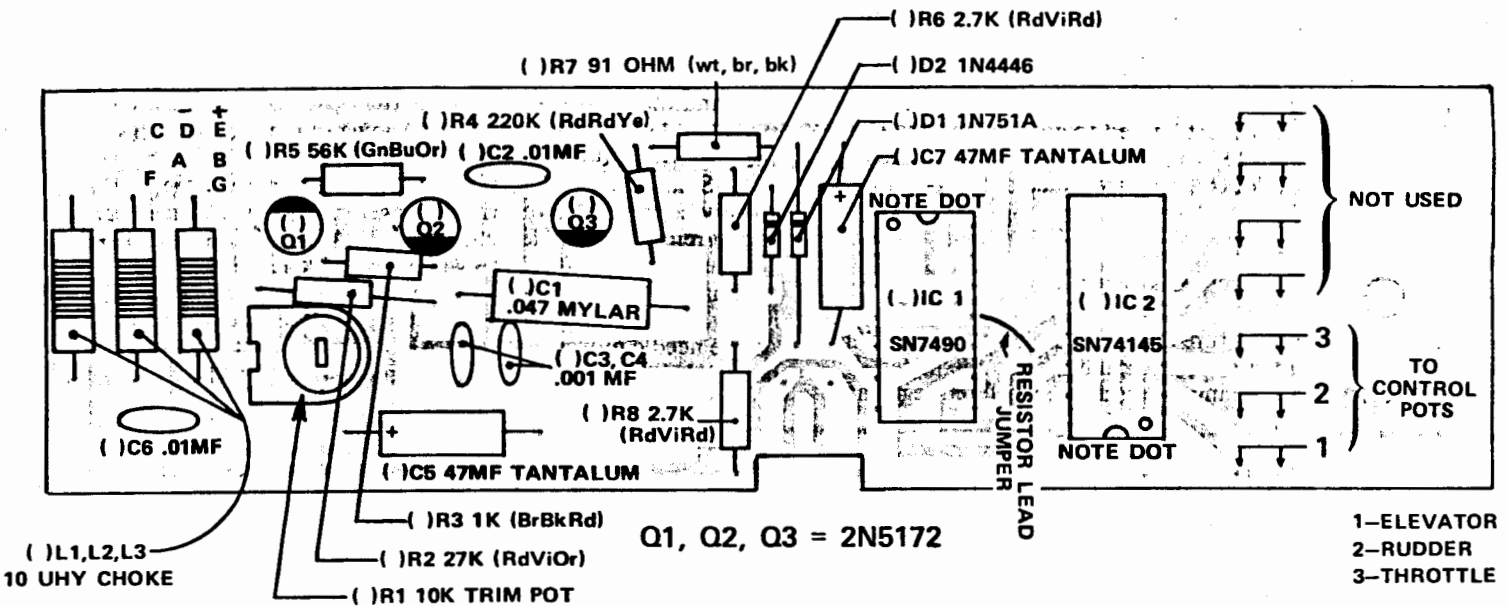
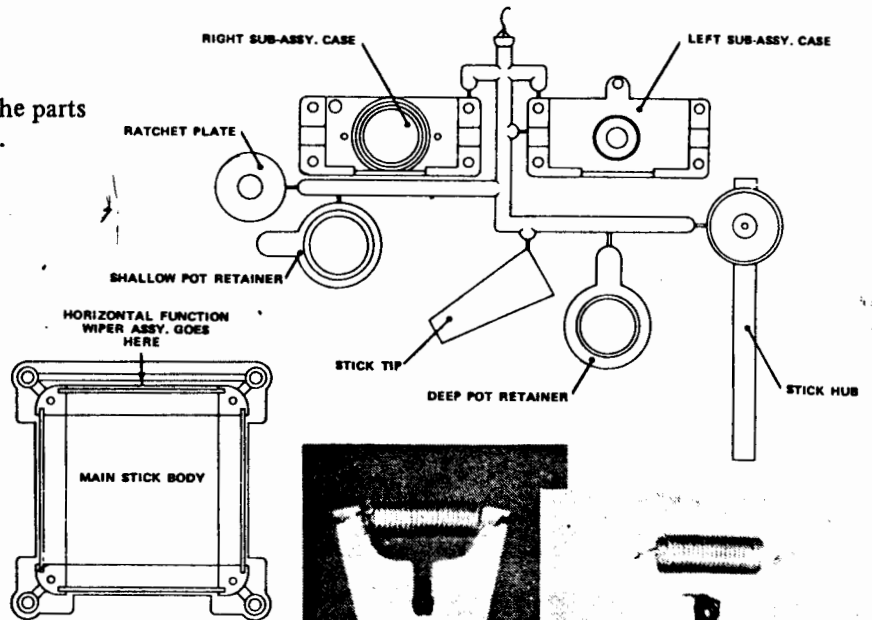
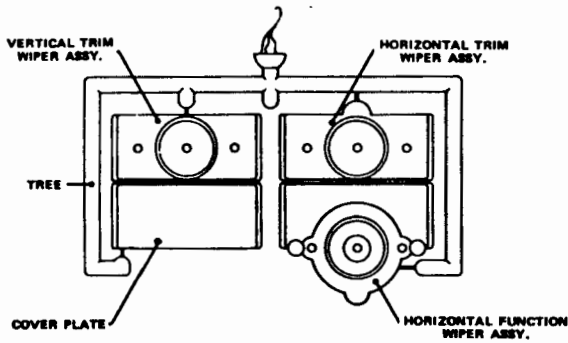

FIGURE C  
ENCODER OVERLAY

**NOTE: INSTALL IC 1 AND IC 2 FIRST AND CONTINUE INSTALLING THE COMPONENTS WORKING FROM RIGHT TO LEFT. NOTICE THE ORIENTATIONS OF THE BANDED ENDS OF THE DIODES, THE POSITIVE (RED) ENDS OF THE TANTALUM CAPACITORS, AND THE FLAT SIDES ON THE TRANSISTORS.**

## IV. TWO AXIS STICK ASSEMBLY

( ) 1. Using an X-acto knife, carefully trim all the parts off the "trees". Trim away any flash left on the parts.



( ) 2. Place a metal scissors on the stick hub; next, slip on a large teflon washer and then another scissors. Using a needle nosed pliers put a spring between the two scissors making sure they are on the "step" on the hub and they are against the stop pin in the proper orientation.

( ) 3. Place the other pair of scissors with a teflon washer in between on the horizontal function wiper assembly. Make sure the scissors are on the "step" and the stop pins are properly aligned. Install the spring.

( ) 4. Slip the stick hub onto the left sub-assembly case half (the one with the small hole). Make sure the scissors engage the stop pin on the case half.

( ) 5. Put the right sub-assembly case half into place and join them together with four 2-56 X 3/8" bolts.

( ) 6. Push the ratchet plate onto the stick hub with the smooth side to the outside, leaving about 1/16" between the ratchet plate and the sub-assembly body. Secure with a 2-56 X 3/16" bolt and washer. NOTE: If the assembly you are building is to be for throttle (ratcheted), remove the spring and tighten the screw down until the ratchet is engaged and the desired amount of tension is reached. If you want just drag on the stick and not a ratchet, turn the ratchet plate around so the smooth side is against the sub-assembly and tighten down until the desired tension is reached.

( ) 7. With a toothpick, apply a small amount of pot lube (supplied in a capsule) to the element of a 5K pot—marked 502—and smooth it on with your finger. There should be enough lub to make the element look wet but no more; if there is too much, the wiper will hydroplane over the lube and make erratic contact.

( ) 8. Make sure the wiper contacts in the sub-assembly are about 3/32" from the wiper carrier. Bend out if necessary. Put the lubricated 5K pot in place with the element against the wiper and with the notch in the pot directly opposite the spring. Put the shallow pot retainer over the pot, making sure the notch in the pot engages the tab in the retainer; secure the pot and pot retainer in place with two 2-56 X 3/16" bolts and fiber (black) washers. Tighten until the pot is firmly in place but can still be adjusted by moving the tab on the pot retainer.

( ) 9. Note that in the ends of the sub-assembly there is a hole with square corners and a hole with rounded corners. Firmly push the horizontal function wiper assembly into the square hole until it stops. Slip the horizontal trim wiper assembly into the other hole.

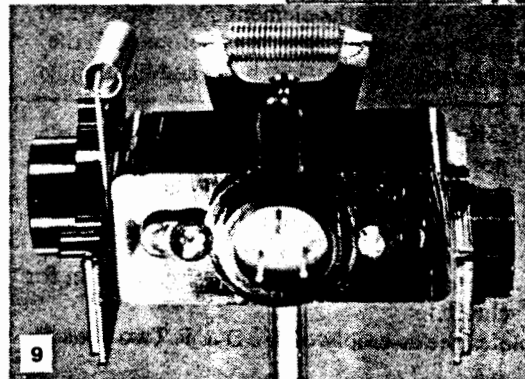
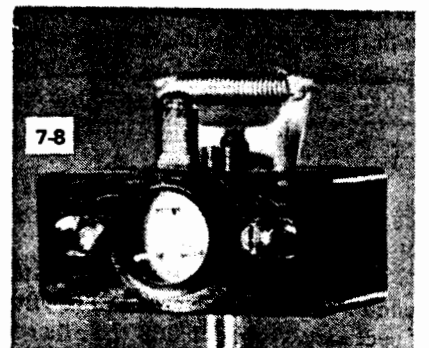
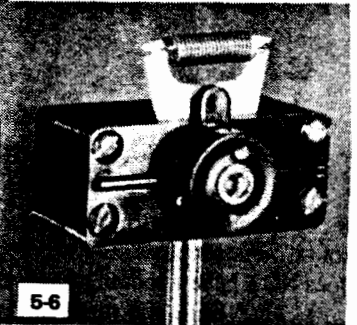
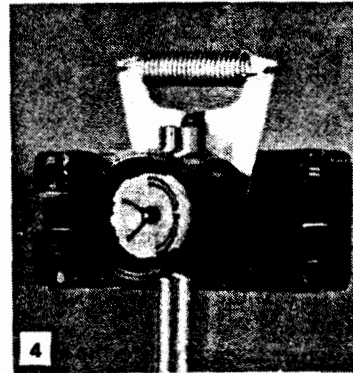
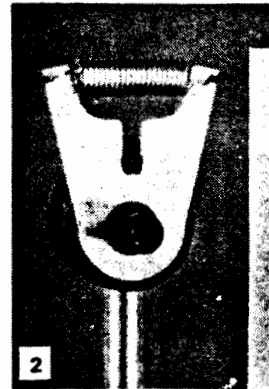

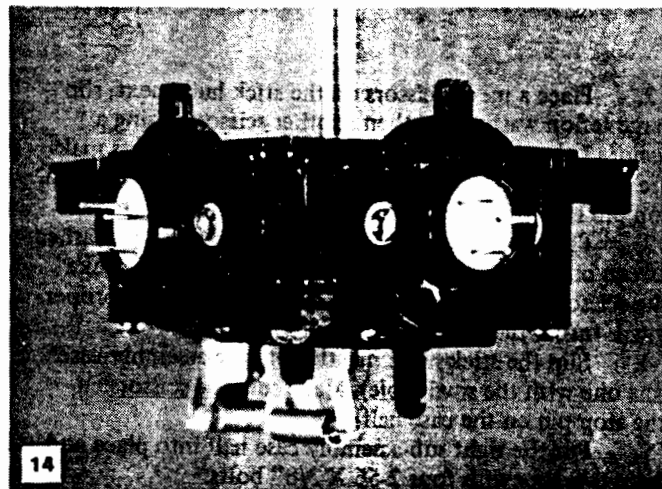
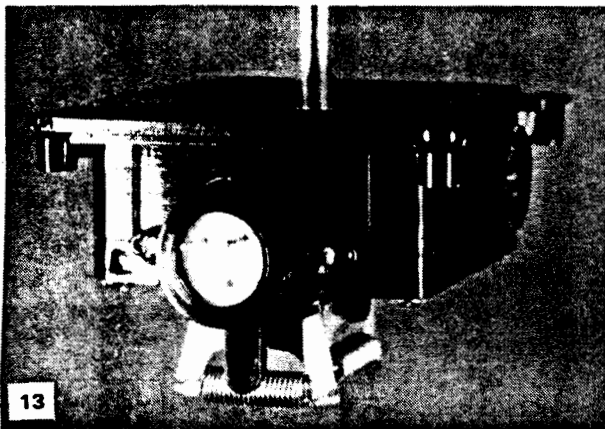
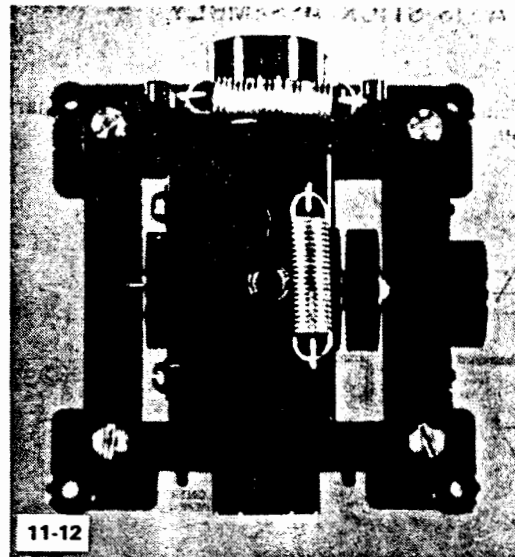
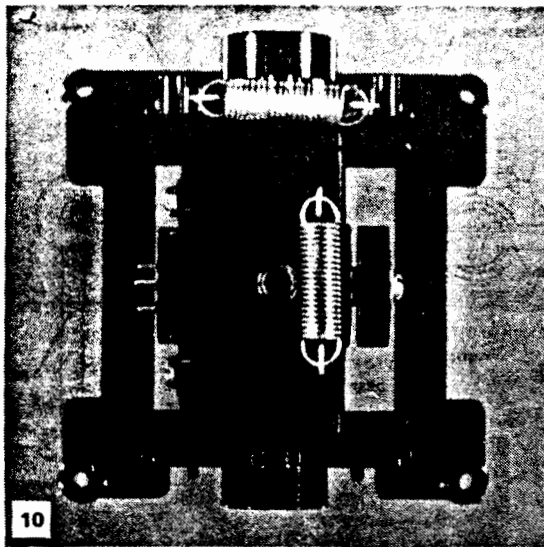

( ) 10. Slip the horizontal function and horizontal trim wiper assemblies into the main stick body. Note that the horizontal function assembly is on the side of the main body that does NOT have a rectangular cut-out.

( ) 11. Slide the vertical trim wiper assembly into the slot on the right of the main body as you face the rear of the stick with the horizontal function wiper assembly on the top. Note that there are lips on three of the trim assembly edges and one flat edge; the flat edge goes to the rear of the main body.

Slide the cover plate into place on the left. Keep the flat edge to the rear.

( ) 12. Secure the sub-assemblies in the main body with the retainer plate and four 2-56 X 3/8" bolts. Note that it can only fit properly one way.

( ) 13. Make sure the wiper contacts on the horizontal function assembly are about 3/32" from the carrier; bend out if necessary. Apply lube to the other 5K pot (502) and put it on its seat in the assembly with the element against the wiper and the notch opposite the spring. Secure as before with the deep pot retainer and two 2-56 X 3/16" bolts and black fiber washers.

( ) 14. The 1.5K trim pots (marked 152) are already secured in the trim pot housings. Apply a small amount of lube to the element and spread it out. After making sure the wiper contacts are bent out sufficiently, mount the trim housings to the stick as shown, using two 2-56 X 3/16" bolts and teflon washers (white) for each. Tighten until the desired tension for the trim lever is achieved.

This completes the assembly of the D & R Two Axis Stick Assembly.

## V. SINGLE AXIS STICK ASSEMBLY

( ) Repeat steps 1-8 for the Two Axis Stick Assembly, noting that the wiper is positioned just the opposite than shown in the photos and that you are building for throttle use (Step 6).

( ) Insert the mounting ears into the holes in the ends of the sub-assembly. This completes the assembly of the Single Axis Stick.

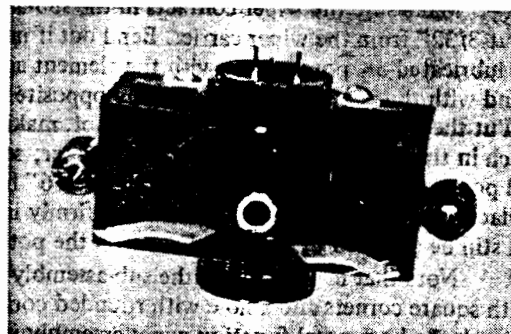

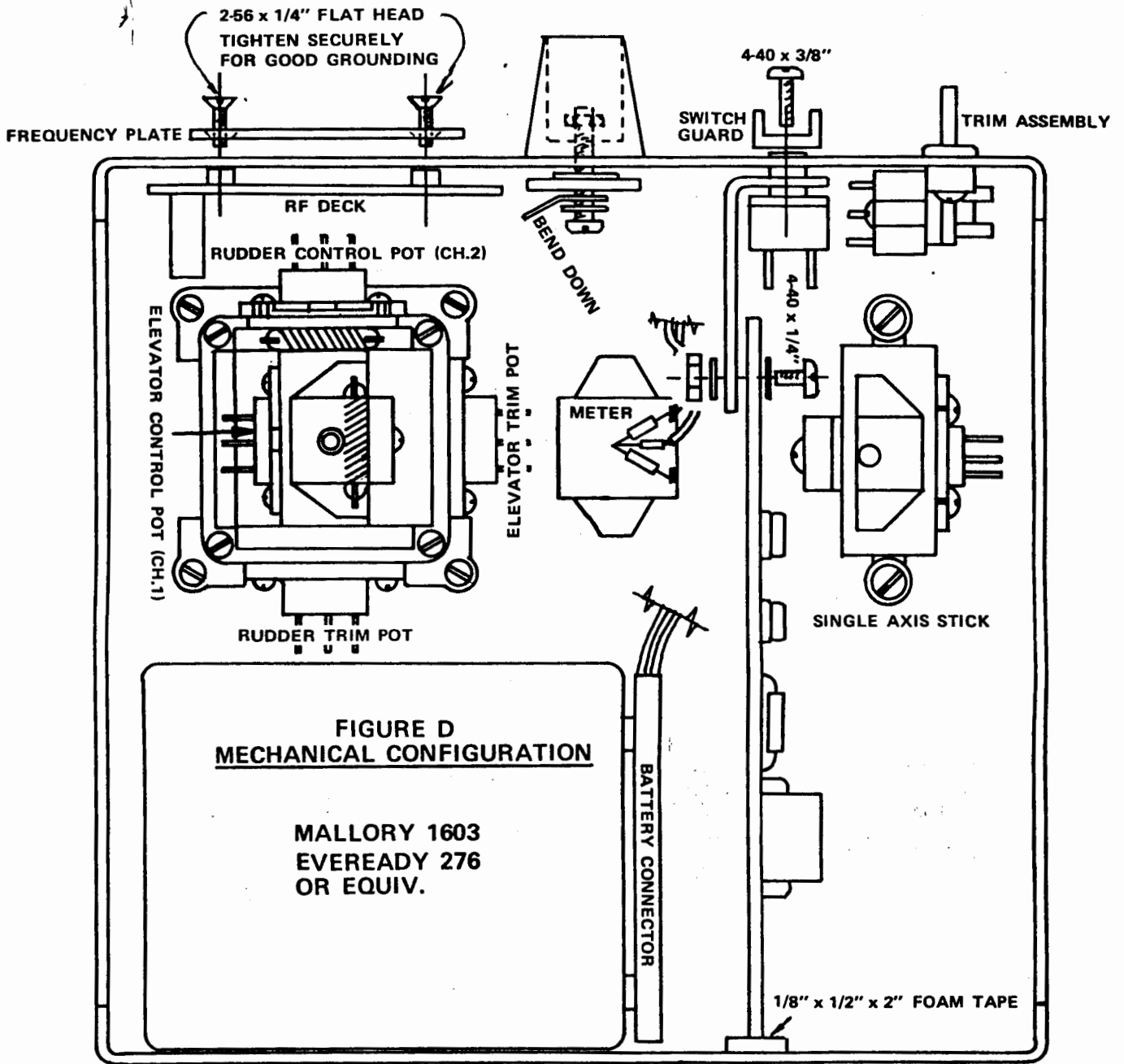

## VI. MOUNTING THE HARDWARE

( ) Mount the switch guard, encoder board bracket and DPDT switch as shown in Figure D using two 4-40 X 3/8" bolts.

( ) Install the antenna mount as shown. You may need to wedge a small screwdriver between the nut and the mount to hold it while tightening. Tighten securely!

( ) Mount the meter in place by removing the backing from the double sided tape and sticking it in place with the green portion of the meter face plate to the top--the lugs should be on the right as you face the rear of the meter.

( ) Do not mount the stick assemblies or the trim assembly yet.

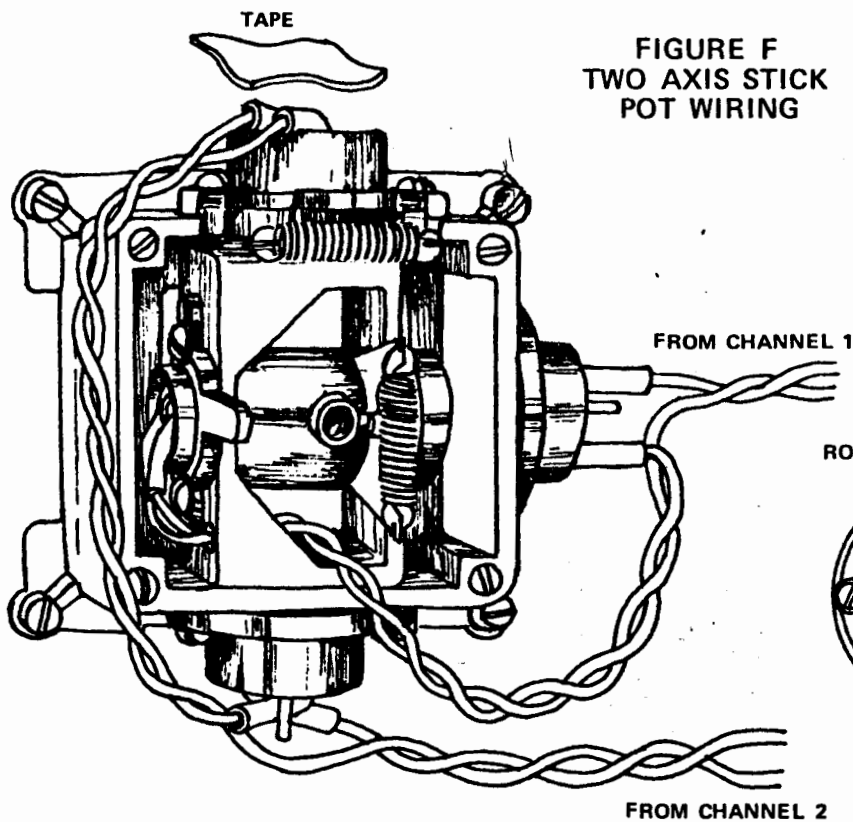
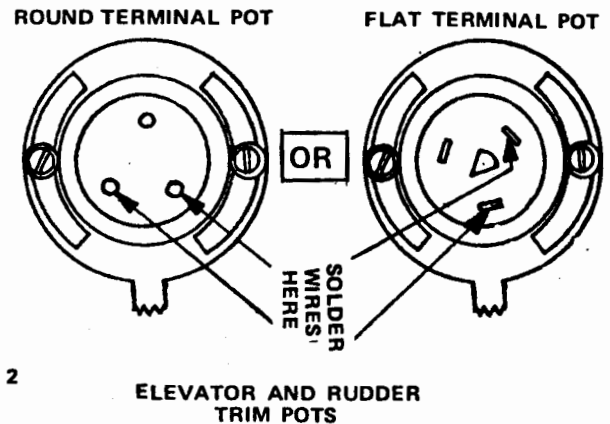
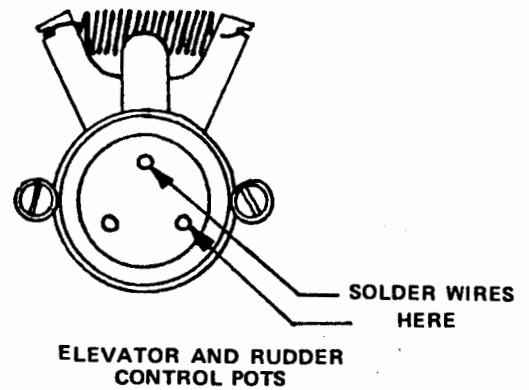

FIGURE F  
TWO AXIS STICK  
POT WIRING



## VII. WIRING

- ( ) Re-read the Wire Preparation section in the "Kit Builder's Hints".
- ( ) Place the two axis and the single axis stick assemblies in position as shown in Figure D. Do not secure in place yet.
- ( ) For the following steps when you need to determine the proper length for the wire, temporarily place the encoder in its proper location in the transmitter case. Don't secure it into position until the stick wiring is complete.
- ( ) Install two 8" pieces of grey wire in the holes indicated for Channel 1 on Figure C. Twist them together.
- ( ) With the encoder board and two axis stick assembly temporarily in position, thread the pair of grey wires between the encoder board and the case front. Run them over to the elevator trim pot and, allowing some slack, cut one of the grey wires in the pair and solder the resulting ends to the elevator trim pot terminals indicated in Figure F. Cover the connections with sleeving.
- ( ) Thread the loose end of the pair of grey wires through the hole in the sub-assembly and solder them to the terminals indicated on the elevator control pot. If the spring which centers the sub-assembly is temporarily removed, the job is easier. Bend the pot terminals over flat so they clear the main stick body when the stick is moved right and left. Reinstall the spring.
- ( ) Repeat for Channel 2 using a pair of 10" grey wires. Run them over to the rudder trim pot, cut one of the pair and solder the ends to the pot, and then solder the end of the pair to the rudder control pot as shown (use sleeving). After the wires are installed on the rudder control pot, bend the pot lugs over flat, especially the one that doesn't have a connection on it. Put a 1/2" square of plastic tape over these connections to prevent any electrical shorts when the RF deck is installed.
- ( ) Mount the two axis stick in the case using the face plate and four 2-56 X 3/8" screws.

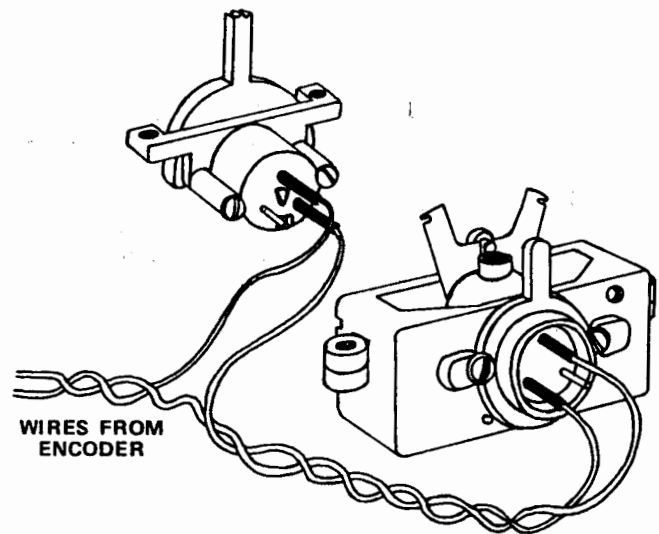

FIGURE G  
SINGLE AXIS STICK/TRIM ASSEMBLY  
POT WIRING

- ( ) Solder two 3" pieces of grey wire into the encoder board holes marked Channel 3 on the overlay. Twist together.
- ( ) Solder one of these wires to the appropriate lug on the pot in the single axis stick assembly and the other to the appropriate lug of the pot in the trim assembly. Cover the connections with sleeving. (Figure G)
- ( ) Solder a 2" piece of grey wire between the trim assembly pot and the single axis stick, covering the connections with sleeving (Figure G). Do not secure either the trim assembly or the single axis stick assembly until after the switch is wired.



( ) Remove the backing from and install a 2" piece of 1/8" foam tape in the bottom of the case, 1 3/4" from the right edge.

( ) Secure the encoder board in the case, using the 4-40 X 1/4" bolt, nut, and lock washers. While tightening the bolt, wedge the bottom of the encoder board firmly against the foam tape to hold it in position. (Figure D)

( ) Solder a 6 1/2" piece of black wire into hole A of the encoder board and a 6 1/2" piece of red wire in hole B of the encoder board (Figure D) and twist together.

( ) Slip a 1/2" piece of 1/8" heat shrink tubing over the other end of the black coming from hole A and solder it to lug 2 of the switch (Figure H). Cover the connection and shrink the tubing down with the soldering iron.

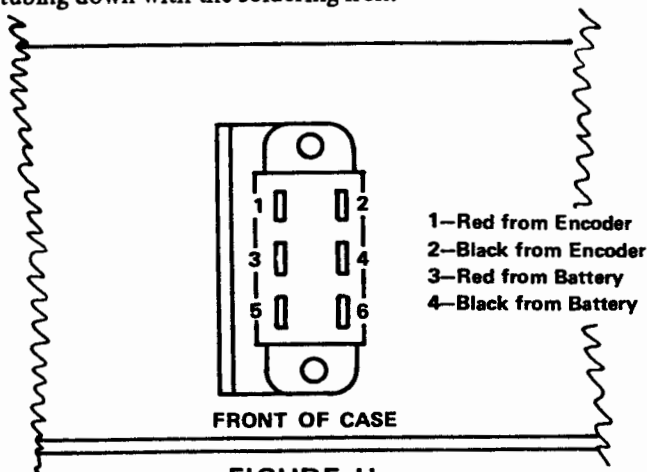

FIGURE H  
SWITCH WIRING

( ) Repeat for the red wire coming from hole B and solder it to lug 1 on the slide switch.

( ) Cut the red and black wires of the battery connector to 5". Slip a 1/2" piece of 1/8" heat shrink tubing over the black wire and solder it to lug 4 on the slide switch. (Figure H) Cover the connections with the tubing and shrink it down with the iron.

( ) Repeat for the red wire, soldering it to lug 3 on the switch.

( ) Solder the black wire coming from the meter into hole F of the encoder board.

( ) Solder the red wire coming from the meter into hole G of the encoder board.

( ) Secure the trim assembly in the case using the two No. 2 X 3/16" self taps furnished. (Figure D)

( ) Secure the single axis stick assembly in place with the 2-56 X 3/8" screws furnished. (Figure D)

( ) Solder an 8" piece of green wire into hole C of the encoder board, an 8" black wire into hole D, and an 8" piece of red wire into hole E. Twist them together.

( ) Solder the other end of these three wires into the appropriate holes in the RF deck as shown in Figure I.

( ) Solder two 1" pieces of grey wire into the RF deck where shown for the antenna.

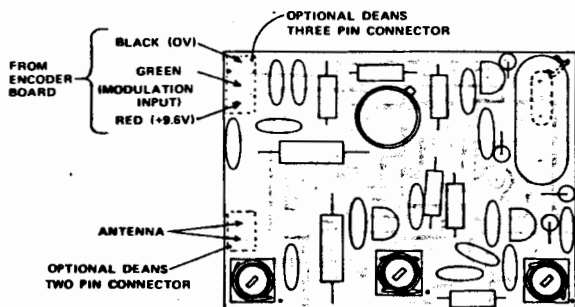

FIGURE I  
RF DECK  
WIRING

\*RED DOT

If desired, you may wire the RF deck up with Deans plugs to permit easy removal for quick frequency change. This is an option and the plugs are not furnished.

Obtain one pair each of the Deans two pin & three pin connectors. Drill out the wire holes in the RF deck to accept the connector and solder the male half of each connector onto the RF deck and the female halves to the wires coming from the encoder board and the antenna. Use insulation sleeving on the females. Make sure that the proper wires make the correct connection to the RF board when the connectors are plugged together. Also make sure the legs on the connectors don't short out on the transmitter case when the RF deck is installed.

( ) Mount the RF deck and the frequency I.D. plate on the transmitter case using two 2-56 X 1/4" flat head bolts as shown in Figure D. The crystal should be on the left as you look inside the back of the case. Tighten securely to insure good ground. Make sure the antenna lug is not shorting to the RF deck and that no leads on the RF deck are touching the transmitter case. Also make sure nothing shorts out between the RF deck and the aileron control pot on the stick assembly.

( ) Solder the two 1" pieces of purple wire coming from the RF deck to the solder lug on the antenna mount.

## VIII. TRANSMITTER SET-UP

Using a VTVM or a solid state VOM of at least 20,000 ohms per volt, set the following pot resistances to the following levels. Make sure the power remains off.

( ) Clip the common (-) lead of the ohmmeter to the encoder PC board so it makes contact with the land indicated in Figure J.

( ) Using a probe on the positive (+) lead of the ohmmeter, make connection with the appropriate exposed leg of IC-2 for channel 1 (pin one). Adjust the elevator function pot on the axis stick assembly by moving the pot adjust lever until the ohmmeter reads 1.7K ohms. Make sure the stick and the trim are in neutral. Repeat this procedure for channels 2 and 3, taking the resistance reading off of pins 2 and 3 and adjusting the rudder and throttle pots. Make sure all trims are in neutral and center the throttle stick.

( ) Taking the resistance reading off of the two test points indicated for the pot on the encoder board, set the pot to read 2.9K ohms. Refer to Figure J.

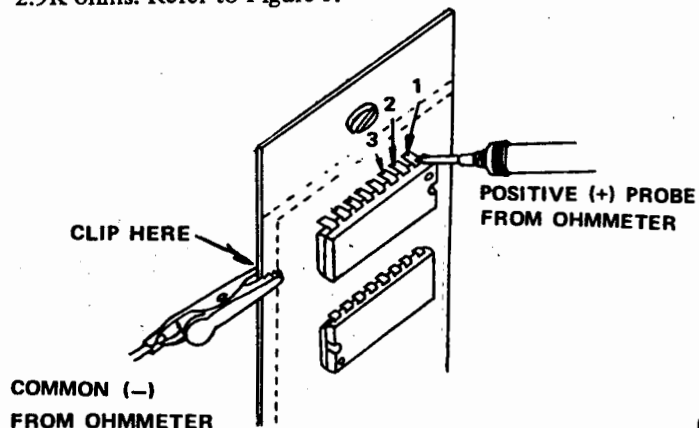
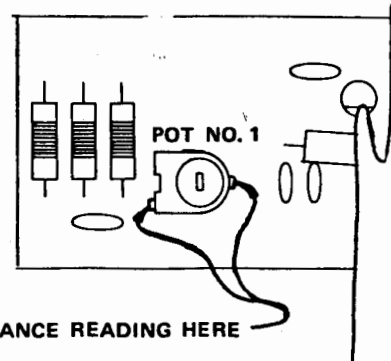

FIGURE J  
TEST POINTS



TAKE RESISTANCE READING HERE

## IX. FINAL ALIGNMENT

( ) Install a 9V dry battery (Eveready 276, Mallory 1603, or equiv.) in the transmitter.

( ) The transmitter can now be turned on and should be operational. Don't operate the transmitter for extended periods (over five or ten minutes) with the antenna off or in the collapsed state. This puts undue strain on the output transistor in the RF deck.

( ) Assemble the receiver/decoder now and tune it to the transmitter according to the instructions.

To set up the time base of the transmitter, you have been furnished one assembled servo which has been neutralized at 1.5 ms and rotates thru 90° with 1 ms pulse width variation. Do NOT change this neutral setting on this servo. If you are building the transmitter separately, you will have to use your existing flight system or an oscilloscope to set up the time base.

( ) Plug the assembled master servo into output 1 of the decoder. With the system on, the servo should operate when the elevator function on the transmitter is moved. If the servo is not centered when the stick and trim are neutralized, adjust pot No. 1 on the encoder board until the servo centers. Move the stick and trim to the extremes—the servo should move through approximately 45° on both sides of neutral.

( ) Plug the master servo into the remaining channels and adjust the TRANSMITTER CONTROL POTS to achieve center on the servo. Do not change the centering of the master servo.

( ) Assemble the remaining servos and plug each one into channel 1 and center it by adjusting it through the output shaft. Each should move approximately 45° on either side of neutral.

( ) Plug the servos into the appropriate channels and operate the sticks. If more servo throw is desired on all channels, lower all stick pot neutral resistances by 200 ohms. In other words, if you aren't getting enough throw with a 1.7K neutral resistance, lower all stick pots to 1.5K neutral resistance. Pot No. 1 will have to be readjusted to recenter the master servo on channel 1 and then all other control pots will have to be readjusted to center the master servo on all channels. Remember not to change the feedback pot setting on the master servo. Repeat if still more throw is desired.

If less servo throw is desired, raise the neutral resistance by 200 ohms and repeat the centering procedure.

Note: Subject to linearity and tolerance of the control pots, the pulse width variation from channel to channel and from neutral to one extreme or the other may vary  $\pm$  5%.

The system is now ready for installation. If a glider or power plane is to be flown, a full range check with transmitter antenna extended should be made. Have a helper walk out with the transmitter with the antenna held upright while slowly and steadily moving one control back and forth. Caution him not to move the other controls as it is desirable to use their steadiness as an indication of solid operation. Hold the model at head level and check operation to a range of around 500 feet. Solid operation to this point is an indication of solid operation to an air distance several times greater.

It's always a good idea to test a new system in an old "test bed" airplane in case there is a problem which doesn't show up on the bench. Also it's good practice to cycle (charge and discharge) the batteries a few times to check them out.

Good luck with your Digital Commander. We at Ace R/C are proud of the quality of components and of the design from both an electrical and a mechanical standpoint. We hope you enjoyed building the Digital Commander and hope you have years of dependable, satisfactory operation from your system. We would appreciate any comments you might have on the building or operation of your system.