

SPECIFICATION AND INSTRUCTION SHEET
FOR THE SATURN RECEIVER

INTRODUCTION

The Saturn is a single-channel, super-regenerative, tone receiver of the highest quality. It supersedes the well-known and original 3-volt receiver, the RTL-3V. Into the Saturn is poured the experience gained from the various versions of the RTL-3-V and all the engineering improvements possible. This receiver is designed to provide the R/Cer with maximum reliability, simplicity of installation indestructible ruggedness minimum battery requirements and minimum size and weight. It is extremely sensitive and is designed for operation over the greatest temperature range of any transistor R/C super-regenerative receiver on the market.

DESIGN SPECIFICATIONS:

Sensitivity: 2 microvolts typical
Selectivity (R.F.): 400 Kc at 5 microvolts input
Audio Band Pass: 500 cps optimum
Detector Tuning Shift (R.F.): .23 Kc/degree F. typical
Audio Response Shift: 0.4 cps/ degree F. typical
Temperature Operating Range: 0° F. to 130°F. (without reduced sensitivity or extra battery addition).
Relay Current Change: 40 ma typical
Relay Setting: Pull-in 25 ma (optimum)
Idle Current (No Transmitter Carrier): 10 ma 80° F. (typical value only).
Idle Current (Transmitter Carrier on): 6 ma all temperature (typical value only).
Relay Pulse Response: 15 pps (typical) (Not Guaranteed)
Operating Voltage: 3.1 Volts (maximum), Volts (minimum)
Tuning Range: 26 to 29 mc (typical) 2.2

PHYSICAL SPECIFICATIONS:

Weight: 1 3/4 oz. Case & Cover: Aluminum
Length: 2" Blue Anodized
Width: 1 5/16" Printed Circuit Board: Photo-etched one ounce
height: 7/8" bonded copper to glass epoxy
Note: Typical values necessary due to transistor parameter tolerances.

TRANSMITTER REQUIREMENTS:

R.F. Frequency: Any standard citizen's band frequency (excluding 465 mc)
Audio Modulation Frequency: 300 cps to 700 cps. Optimum, 500 cps.
Per Cent Modulation: 80% or more
The F & M Venus transmitter is recommended.

General Remarks:

There are many qualities of the Saturn that would pass unnoticed by the casual observer unless close comparison to competitive equipment is made. Compare the following features of the Saturn:

FEATURES:

- (1) The well-made and attractive case.
- (2) The glass-epoxy printed circuit board-not the commonly used paper epoxy that shatters in cold weather.
- (3) The power relay-strong spring settings and high current changes replace the highly sensitive and malfunctioning relay of yesterday. No more constant adjusting or cleaning.
- (4) The narrow audio band pass which offers unusual unwanted signal rejection for a super-regenerative type receiver.
The likelihood of destructive interference is lessened,
- (5) THE GUARANTEED TEMPERATURE OPERATING RANGE OF 0°F to 130°F.

- (6) The ability to operate from the 3 volt batteries powering the actuator.
- (7) The top grade first quality components used throughout; no factory reject for foreign-made components.

OPERATING INSTRUCTIONS:

Batteries: The Saturn is designed to be powered by either dry cells or rechargeable batteries.

Dry Cells: Two pen-cells or two sub-miniature pen-cells will supply all the power required by the receiver for many, many flights without replacement. The Saturn will operate without chattering from the 3-volt actuator batteries and such operation is recommended for lightweight installations. If the actuator requires more than 3V, the receiver voltage must be limited to 3V. Therefore, separate supplies may be used or the receiver power tapped from only two of the actuator batteries. The receiver batteries should be replaced when the voltage drops to 2.2 volts under load.

VO Batteries: Two Ni-Cad batteries, series connected, are highly recommended for powering the Saturn. By using 250 MAH or 500 MAH batteries, both the receiver and actuator (one or more) may be powered by the same batteries. Two 180 MAH are more than adequate for powering the receiver alone. Care should be exercised in battery installation since a reversed polarity could damage the receiver.

Antenna: The antenna length for the Saturn is not a critical and may vary from 18" to 36" (anything longer being too inconvenient and anything shorter too inefficient). An average antenna (measured from receiver case) would be 26" to 30". Remember the longer the antenna the greater the range. A vertical piece of piano wire mounted directly behind the wing is recommended. Horizontal antennas, though satisfactory, may exhibit directional effects.

Installation: The Saturn may be mounted in any convenient position within the model. A very suitable installation is acquired by mounting the receiver vertically base forward against a bulkhead. The receiver should be shock-mounted with $\frac{1}{2}$ " of foam rubber between the base and the bulk-head and held in place with rubber bands strapped over the case. Other equally suitable arrangements may be devised. Wire according to your requirements. Solder all connections securely and do not depend upon the solder to hold the wire to the terminal; always wind the wire around the terminal first then solder it. Use a good grade of rosin core solder. Under no circumstances use acid core solder.

Spark Suppression: Spark suppression is absolutely necessary to prevent relay contact burning due to the high inductive kick of actuators. One of the simplest and best methods of spark suppression is to connect a 100-ohm, $\frac{1}{2}$ watt resistor directly across the motor or escapement power terminals.

Tuning and Testing: Upon completion of the wiring, double check to make certain that it is correct and that spark suppression has been installed.

The Saturn is pretuned at the factory and only minor readjusting should be required to peak it up.

TUNING:

The recommended and most accurate, tuning procedure is as follows:

- (1) Position the receiver switch 'ON'. With the transmitter antenna fully collapsed, turn on the transmitter and press the key. The receiver should respond. If no response, rotate tuning adjustment until response occurs. One-half turn in either direction should be sufficient.
- (2) Remove the antenna from the F & M transmitter. Position the transmitter within an inch of the receiver antenna-- the open antenna hole pointed directly at the receiver antenna. Key the transmitter. Receiver response probably will be obtained. If not adjust tuning slug until response is obtained. Center tuning slug in the response range.
- (3) Position the transmitter further from the receiver antenna and recenter the adjustment. Continue working away and recentering until maximum range is reached and tuning is quite critical. The distance from the transmitter antenna hole to the receiver antenna is normally one foot or more at this point. Tuning is now complete.

The above tuning method is extremely simple and very accurate. It requires no special tools (except the tuning wand) and offers a quick means of checking receiver operation before flight.

An alternate method of tuning is provided by using a milliammeter (0-100 ma scale. Insert the meter in series with one of the power leads to the receiver (see wiring diagram). When the receiver is energized the meter should read approximately 8-12 ma. When the transmitter is turned 'ON' this reading should drop to approximately 6 ma. When the transmitter is keyed, the reading should rise to 35-50 ma. Tune the receiver for a maximum reading of the meter with the transmitter keyed. Remove the F & M transmitter antenna and key the transmitter as close to the receiver antenna as necessary to give about 30 ma reading on the meter. Fine tune the receiver for a maximum meter reading. The meter leads must be kept as short as possible to prevent influencing the tuning adjustment.

CAUTION : MOST IMPORTED AND SOME INEXPENSIVE AMERICAN METERS WILL INTRODUCE EXCESS SUPPLY RESISTANCE AND CAUSE OSCILLATION. RELAY WILL PULL IN WITH NO SIGNAL WHEN THIS HAPPENS. USE OTHER TUNING METHOD.

Receiver tuning should be accomplished with an all plastic tuning tool-- no metal ends. The receiver cover must be on and all wiring complete. Once accomplished, retuning should not normally ever be necessary unless the wiring is changed. Temperature compensating components correct temperature effects.

Field Use: Range check the equipment prior to flight. One quarter mile of ground range should be considered sufficient, although considerably more is usually the case. Much depends on the installation.

Receiver blocking, due to transmitter proximity, is reduced to the absolute minimum with the Saturn. This should not be a problem.

WARRANTY:

Our standards written 30 day warranty card accompanies each unit. F & M Electronics maintains a fully trained staff for the prompt repair of your F & M equipment. All repair charges are itemized and nominally priced.

SPECIFICATIONS AND INSTRUCTION FOR THE SATURN AND MERCURY RECEIVER -----

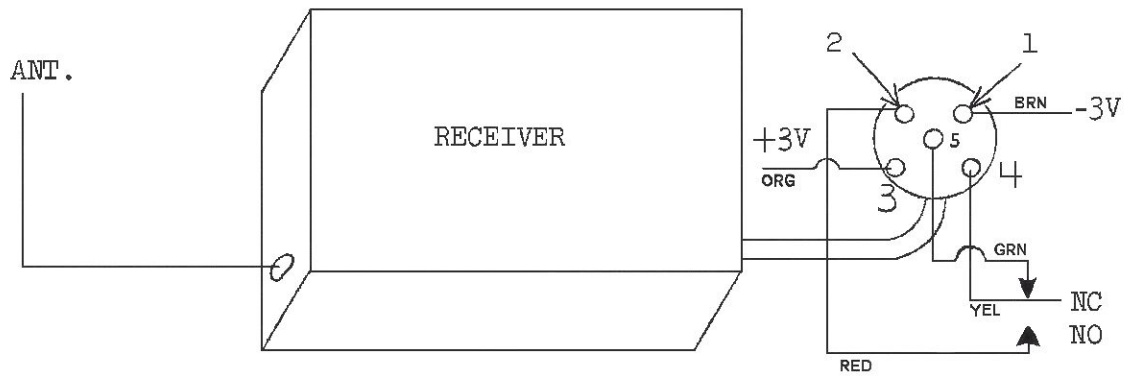

SINGLE BATTERY INSTALLATION:

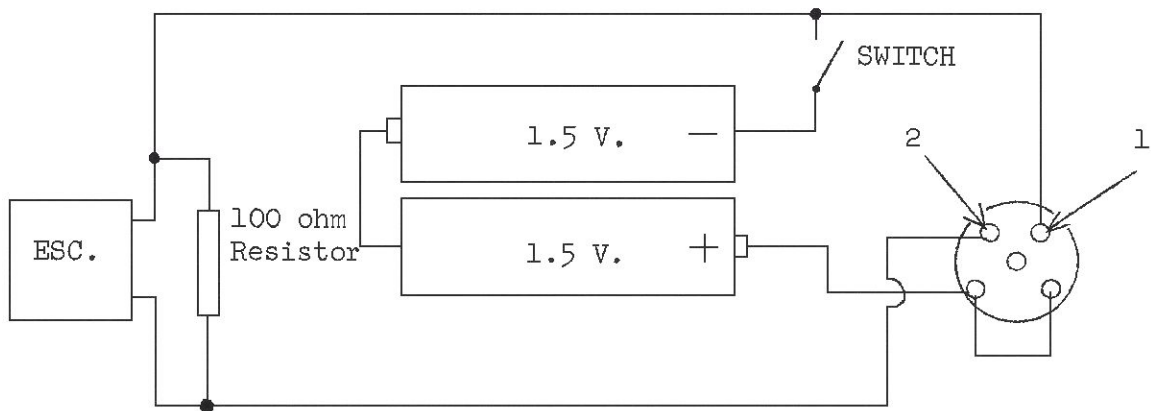

INSTALLATION USING TWO SETS OF BATTERIES:

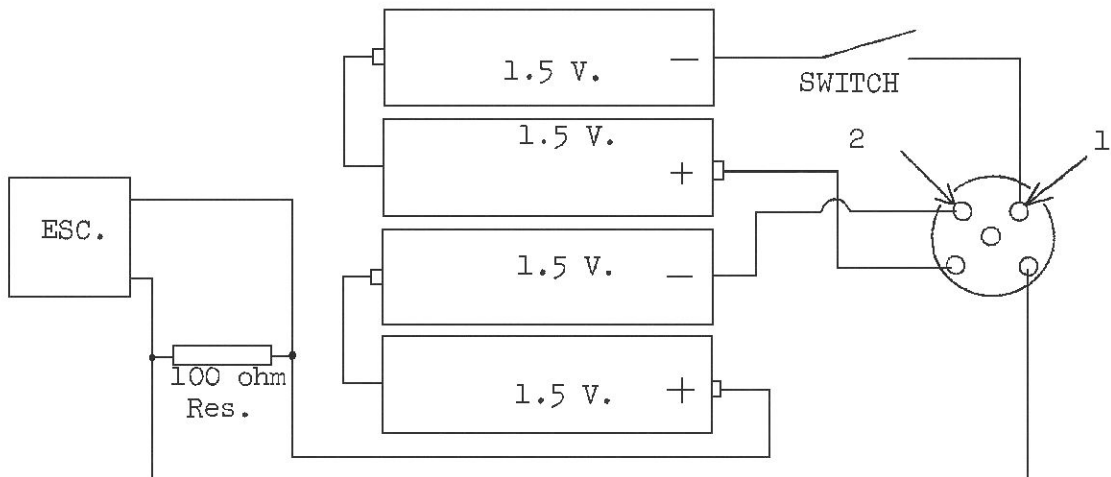

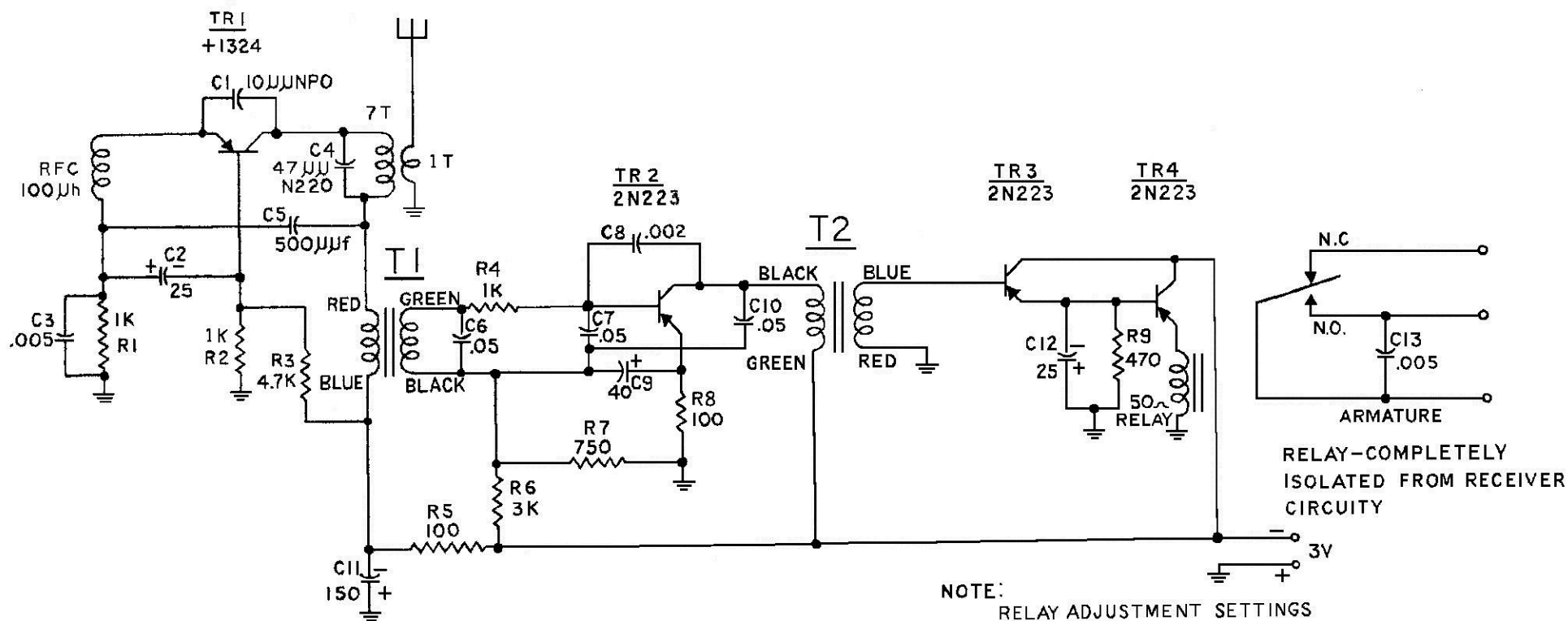

NOTE:
 RELAY ADJUSTMENT SETTINGS
 MAX PULL-IN - 24ma
 OPTIMUM PULL-IN - 20ma.
 MINIMUM DROP-OUT - 18ma.